

High-performance centrifugal bathroom fans, slim version, to be installed in ceilings or walls.

CB-100 PLUS / CB-250 PLUS



CB-100 PLUS



CB-250 PLUS

- **CB-100 PLUS** totally recessed.
- Finishing: white.
- **CB-250** with short tube.
- Modern slim version.
- Centrifugal impeller for high pressure, which need to be passed in longer ductings.
- Back-draught shutters included.
- Plastic housing and impeller.
- 230 V, 50 Hz motors, protection **IP-X4**, insulation class **B** and thermal cut out, ambient temperature max. 40°C.

CODE	MODEL	VERSION	Ø (mm)	Voltage (V)	Speed (r.p.m)	Input Power (W)	Maximum AirFlow (m3/h – l/s)	Sound Pressure Level dB(A)	Weight (Kg)	Units per Box
TIMER SERIES										
00841000	CB 100 PLUS T	●	100	230	2.300	25	130	49	0,98	5
00851000	CB 250 PLUS T	●	100/120	230	2.500	45	270	52	1,64	5
STANDARD SERIES										
00840000	CB-100 PLUS	●	100	230	2.300	25	130	49	0,98	5
00850000	CB-250 PLUS	●	100/120	230	2.500	45	270	52	1,64	5

DIMENSIONS mm

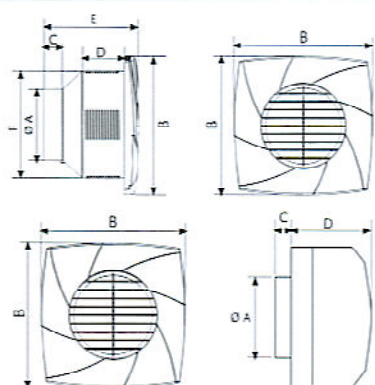

	Ø A	B	C	D	E	F
CB-100 PLUS	97,6	190	26	57,4	129,4	147,8

	Ø A	B	C	D
CB-250 PLUS	96/118	208	17	122

* Double outflow diameter included.

Versions



STANDARD

In combination with light, fans switches on.



TIMER

Electronic timer adjustable from 3 to 15 minutes.